



PL18 Owner's Manual



AERATOR Owner's Manual

PL1800H and PL1800V

U.S. PATENT #6892821

Replacement Parts

TINE REPLACEMENT

Replacement tip for aerating tines.

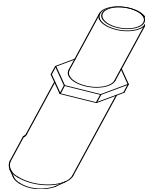

P/N 381057

TINE BUSHING REPLACEMENTS

Replacement bushings for the tines

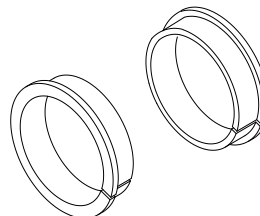

P/N 380213



PL18 Owner's Manual

CONTENTS

SPECIFICATIONS	3
INTENDED USE	4
INSTRUCTION LABELS	5
PACKING CHECKLIST & ASSEMBLY	6
OPERATION	7
MAINTENANCE AND TROUBLE SHOOTING	8
WARRANTY INFORMATION	9
ILLUSTRATED PARTS & PARTS LIST	10-11



PL18 Owner's Manual

SPECIFICATIONS

	PL1800V	PL1800H
Engine: cc	205cc	118cc
Engine:	B&S 5.5hp Intek w/Gearbox	HONDA GX120 W. gearbox
Engine: Fuel Capacity	3.0 qt. (2.84 L)	2.1 qt. (2 L)
Engine: Oil Capacity	0.66 qt. (0.62 L)	0.59 qt. (0.56 L)
Total Unit Weight:	244# (111 Kg)	240# (109 Kg)
Length	57" (1.45m)	57" (1.45m)
Width	24"(.61m)	24"(.61m)
Height	40" (1m)	40" (1m)
Max. operating slope	15°	15°
Sound test in accordance with 2000/14/EC	102.56	102.56
Sound at operators ear	82.56	82.56
Vibration at operator position	.6g (6.28m/s ²)	.6g (6.28m/s ²)

SOUND



L_{WA}

SOUND LEVEL 82 dB(a) at Operators Position

102

Sound tests were conducted in accordance with 2000/14/EC, and were performed on 9/26/14 under the conditions listed below.

Sound power level listed is the highest value for any model covered in this manual. Please refer to serial plate on the unit for the sound power level for your model.

General Conditions:

Temperature:

Wind Speed:

Wind Direction:

Humidity:

Barometric Pressure:

Sunny

66°F (18.9°C)

8 mph (12.8 kph)

South

78%

30 Hg (101.59 kpa)

VIBRATION DATA

VIBRATION LEVEL .6g (6.28 m/s²)

Vibration levels at the operator's handles were measured in the vertical, lateral and longitudinal directions using calibrated vibration test equipment. Tests were performed on 9/26/14 under the conditions listed below.

General Conditions:

Temperature:

Wind Speed:

Wind Direction:

Humidity:

Barometric Pressure:

Sunny

66°F (18.9°C)

8 mph (14.5 kph)

South

78%

30Hg (101.6 kpa)



PL18 Owner's Manual

INTENDED USE

AERATOR

This machine is designed for aerating established lawns and large grass covered areas. The machine should not be used for any other purpose than that stated above.

⚠ DO NOT OPERATE IF EXCESSIVE VIBRATION OCCURS! If excessive vibration occurs, shut engine off immediately and check for damaged or worn reel, loose reel bearing, loose engine or lodged debris. To remove debris from the machine, see the machine specific trouble shooting section. **Note:** See parts list for proper bolt torque specifications.

HANDLING & TRANSPORTING

Always use two or more people to lift these machines. Lift holding on either side of the machine, using the handles and the frame. Secure in place during transportation. See specifications for unit weight.

 For safety use gloves when lifting.

 Never lift any machine while the engine is running.



PL18 Owner's Manual

INSTRUCTION LABELS

The labels shown below were installed on your BILLY GOAT® Aerator. If any labels are damaged or missing, replace them before operating this equipment. Part numbers from the Illustrated Parts List are provided for convenience in ordering replacement labels. The correct position for each label may be determined by referring to the part numbers shown.

CHECK OIL BEFORE EACH USE.
GREASE ALL FITTINGS EVERY 10 HOURS OF OPERATION.
WE RECOMMEND ALMAGARD® #3752 GREASE FROM LUBRICATION ENGINEERS® INC.

TO AERATE

1. Retract Tines With Center Control Lever.
2. Begin Forward Motion of Aerator Manually.
3. Engage Drive Lever With Aerator Already in Motion.

100354

LABEL PL INSTRUCTIONS
P/N 100354

DANGER

PINCH POINT

100355

LABEL PINCH POINT
P/N 100355

PULL TO ENGAGE TINES
JALE HACIA ARRIBA PARA ENGRANAR LOS DIENTES

100356

LABEL PULL TO ENGAGE
P/N 100356

WARNING

900327

LABEL WARNING GUARD
P/N 900327

DANGER
KEEP HANDS and FEET AWAY

LABEL DANGER
P/N 400424

FORWARD TO LOWER TINES
BACK TO RAISE TINES
AVANCE PARA BAJAR LOS DIENTES

100357

LABEL FORWARD TO LOWER TINES
P/N 100357

ENGINE LABELS

READ OWNER'S MANUAL BEFORE OPERATION.
 LIRE LE MANUEL D UTILISATEUR AVANT USAGE.
 VOR INBETRIEBNAHME UNBEDINGHT BEDIENUNGSANLEITUNG DURCHLESEN.
 NO UTILIZAR SINANTES NO HABER LEIDO EL MANUAL

HONDA MOTOR CO., LTD. MADE IN JAPAN

HONDA

OIL ALERT

WHEN OIL LEVEL LOW,
ENGINE STOPS IMMEDIATELY.

IMPORTANT ENGINE INFORMATION: HONDA MOTOR CO. LTD
ENGINE FAMILY: THN163U1G1RA DISPLACEMENT: 163cm³
TUNE UP SPECIFICATION: REFER TO OWNER'S MANUAL FOR
MAINTENANCE SPECIFICATIONS AND ADJUSTMENTS. THIS ENGINE
MEETS 1995 CALIFORNIA EMISSION REGULATIONS FOR
UTILITY AND LAWN AND GARDEN EQUIPMENT ENGINES

EM TE

THROTTLE CONTROLS

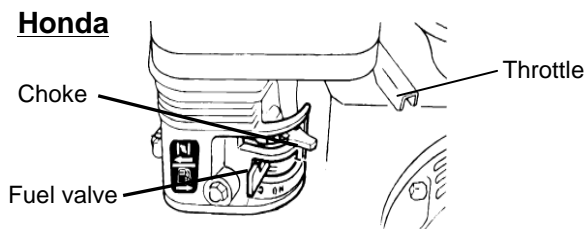

Briggs

Set lever to choke when starting cold

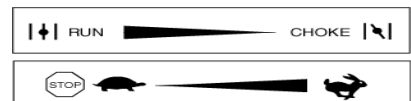

Set lever to desired engine speed.
Move lever completely to the left to stop engine



PL18 Owner's Manual

PACKING CHECKLIST

Your Billy Goat is shipped from the factory in one carton, completely assembled with the cables detached.



READ all safety instructions before assembling unit.
TAKE CAUTION when removing the unit from the box.



PUT OIL IN ENGINE BEFORE STARTING

PARTS BAG & LITERATURE ASSY

Warranty card P/N- 400972, Owner's Manual P/N-100381, Declaration of Conformity P/N-381503, General Safety and Warranty Manual P/N- 100295

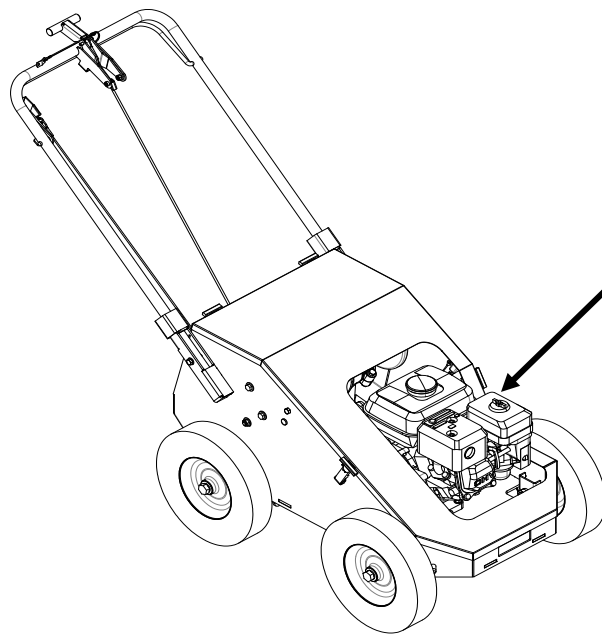

Boxing Parts Checklist

Owner's Manual
100381

Engine Manual Per Model

Honda
 Briggs

ASSEMBLY

NOTE: Items in () can be referenced in the part illustrations and part lists on pages 10-11.

- 1. ATTACH** the tine lift cable (item 17) to the Tine lever (item 38) in the center of the handle by inserting the pin (item 65) into it. Then attach the bail cable (item 30) to the bail (item 42). Check to make sure the cables are functioning properly before operation and not binding.
- 2. CHECK** engine oil level and fill to proper level. Also check oil in gear reduction reservoir and fill if necessary. See engine owner's manual for type and amount of oil to use.
- 3. CONNECT** spark plug wire. Set the engine stop switch located on upper handle, to the **ON** position.

FOLDING HANDLE

This unit is equipped with a folding upper handle for easier storage.

1. Slide handle lock loops (item 24) up on both sides.
2. Fold the upper handle (item 48).



PL18 Owner's Manual

OPERATION

STARTING ENGINE

See engine manufacturer's instructions for type and amount of oil and gasoline used. Engine must be level when checking and filling oil and gasoline.

ENGINE SPEED: Controlled by lever on the engine. Under normal conditions, operate at the minimum throttle speed to accomplish your task.

ON/OFF: Set the on/off switch to ON

FUEL VALVE: Move fuel valve to "ON" position. (Honda: Located below the air cleaner on the engine.)

CHOKE: Engage the choke when starting a cold engine. (Honda: Located below the air cleaner on the engine.)

THROTTLE: Move the throttle control lever on the engine to fast position. Pull starting rope to start engine

If your unit fails to start, check trouble shooting section in operator's manual and also see engine manual. *NOTE:* Honda engines are equipped with a low oil sensor to prevent engine damage. When it senses a low oil condition (i.e. unit is operating or sitting on a steep slope) the engine shuts down. The low oil condition must be corrected before the engine can be restarted. See the engine owner's manual for more information.

AERATING OPERATION

NOTE: NEVER PARK THIS UNIT ON A SLOPE OF ANY KIND. Always keep tines in the up position when parking the unit.

TINES RAISING/LOWERING: The tines are raised or lowered into the ground by operating the tine engagement lever on the upper handle. Tine penetration is very dependent on surface preparation. READ the entire operation section before aerating.

ENGAGE TINES: With the aerator in the work area, lower the tines by releasing the center lever on the handle. When the lever is in the forward position, pull up on the bail to engage the tines.

AERATE: Push the machine with the tines engaged. *NOTE:* In cold temperatures engage the tines in the up position for two minutes to warm the cam grease. For maximum tine penetration apply downward pressure on the handle.

TURNING: At the end of an aerating run, release the bail and raise the tines out of the ground. Then reposition the unit for another pass and lower the tines to begin another run.

TRANSPORT: Be sure to raise tines out of the ground (disengaging the bail and then raising the tines with the center lever) before transporting away from the work area.

*****TIPS*****

MOW

Mow the lawn to its normal cut height.

WATER

For the best performance and maximum tine penetration the lawn should be thoroughly watered the day before aeration.

INSPECT

Check the lawn before beginning work. Remove all rocks, wire, string, or other objects that can present a hazard during work prior to starting.

IDENTIFY

Mark all fixed objects to be avoided during work, such as sprinkler heads, water valves, buried cables, or clothes line anchors, etc.

SLOPES

Do not operate the aerator on steep slopes (exceeding 15°). Use extreme caution when operating on any sloped surface. For lesser sloped areas operate the unit, traversing up and down at a 45 degree angle to the slope rather than straight across. Extended operation on steep slopes can cause engine damage. *NOTE:* Honda engines are equipped with a low oil sensor to prevent engine damage. When it senses a low oil condition (i.e. unit is operating or sitting on a steep slope) the engine shuts down. The low oil condition must be corrected before the engine can be restarted. See the engine owner's manual for more information.



PL18 Owner's Manual

MAINTENANCE

NOTE: Items in () can be referenced in the Part Illustration and Part List on pages 10-11.

PERIODIC MAINTENANCE

Periodic maintenance should be performed at the following intervals:

Maintenance Operation	Every Use (daily)	Every 10 Hrs	Every 50 Hrs	Every 100 Hrs
Inspect for loose, worn or damaged parts		●		
Check engine oil	●			
Inspect belt for wear			●	
Engine (See engine manual)				
Grease Cam bearings		●		
Thoroughly clean all debris from unit and tines	●			
Replace tine bushings				●
Grease shaft bearings and wheel bearings				●

ENGINE MUST BE LEVEL WHEN CHECKING OR FILLING OIL

INDIVIDUAL TINE REPLACEMENT

1. Wait for engine to cool and disconnect spark plug.
2. Loosen the jam nut (item 13) then unscrew the tine (item 14).
3. Replace the tine making sure to use the maximum amount of threads on the tine.

NOTE: Tines are a normal wear item and should be inspected regularly for signs of wear or damage.

ADJUSTING BELT TENSION

1. Loosen the mounting bolts for the engine and then slide it to apply or relieve tension on the belt.

DRIVE BELT REPLACEMENT

1. Disconnect the spark plug.
2. Remove the lower and upper tensioner brackets (items 59 and 60) on both sides of the pulley (item 3).
3. Walk the belt (item 4) off of the engine pulley.
4. Attach a hoist mechanism to the cam shaft (item 44), and then remove the four bolts, washers, and nuts (items 52, 10 and 11) that attach the bearing (item 9) of the cam shaft to the frame.
5. Raise the cam shaft out of the frame and remove the old belt.
6. To replace the belt, simply slide the new belt onto the pulley when the cam shaft is raised then follow the previous steps in reverse to install.



PL18 Owner's Manual

TROUBLESHOOTING

Engine will not start	Stop switch off. Throttle in off position. Engine not in full choke position. Out of gasoline. Bad or old gasoline. Spark plug wire disconnected. Dirty air cleaner. Engine oil level too low (Honda only).	Check stop switches, throttle, choke position and gasoline. Connect spark plug wire. Clean or replace air cleaner. Or contact a qualified service person. Check and fill engine oil.
Abnormal vibration	Damaged or missing tines. Loose handle bolts. Loose engine bolts.	Stop work immediately. Replace any damaged or missing tines. Tighten all loose bolts and nuts.
Engine stalls or labors when aerating	Working on too steep of a slope. Not enough oil in the engine.	Work at 45 degrees to the slope moving up and down instead of across. Check and add engine oil.
Engine is locked, will not pull over	Debris locked against reel, or drive pulleys. Engine problem.	Pull spark plug wire and remove debris. Contact an engine servicing dealer for engine problems.
Unit does not move when clutch is engaged	Belt drive out of adjustment. Worn drive belt. Loose or damaged pulleys. Damaged or broken clutch cable.	See maintenance on pg. 10 of this manual. Contact a qualified servicing dealer.

WARRANTY INFORMATION

When servicing engine refer to specific manufacturer's engine owner's manual. Engine warranty is covered by the specific engine manufacturer. If your engine requires warranty or other repair work contact your local servicing engine dealer. When contacting a dealer for service it is a good idea to have your engine model number available for reference (See table page 3). If you cannot locate a servicing dealer in your area you can contact the manufacturer's national service organization. To reach:

American Honda: 800-426-7701
Briggs and Stratton: 414-479-8008

WARRANTY CLAIM PROCEDURE

Should a BILLY GOAT[®] machine fail due to a defect in material and/or workmanship, the owner should make a warranty claim as follows:

- The machine must be taken to the dealer from whom it was purchased or to an authorized Servicing BILLY GOAT Dealer.
- The owner must present the remaining half of the Warranty Registration Card, or, if this is not available, the invoice or receipt.
- The Warranty Claim will be completed by the authorized BILLY GOAT Dealer and submitted to their respective BILLY GOAT Distributor for their territory Attention: Service Manager. Any parts replaced under warranty must be tagged and retained for 90 days. The model number and serial number of the unit must be stated in the Warranty Claim.
- The distributor service manager will sign off on the claim and submit it to BILLY GOAT for consideration.
- The Technical Service Department at BILLY GOAT will study the claim and may request parts to be returned for examination. BILLY GOAT will notify their conclusions to the distributor service manager from whom the claim was received.
- The decision by the Technical Service Department at BILLY GOAT to approve or reject a Warranty Claim is final and binding.

For online product registration go to www.billygoat.com



PL18 Owner's Manual

PL1800/H PARTS DRAWING

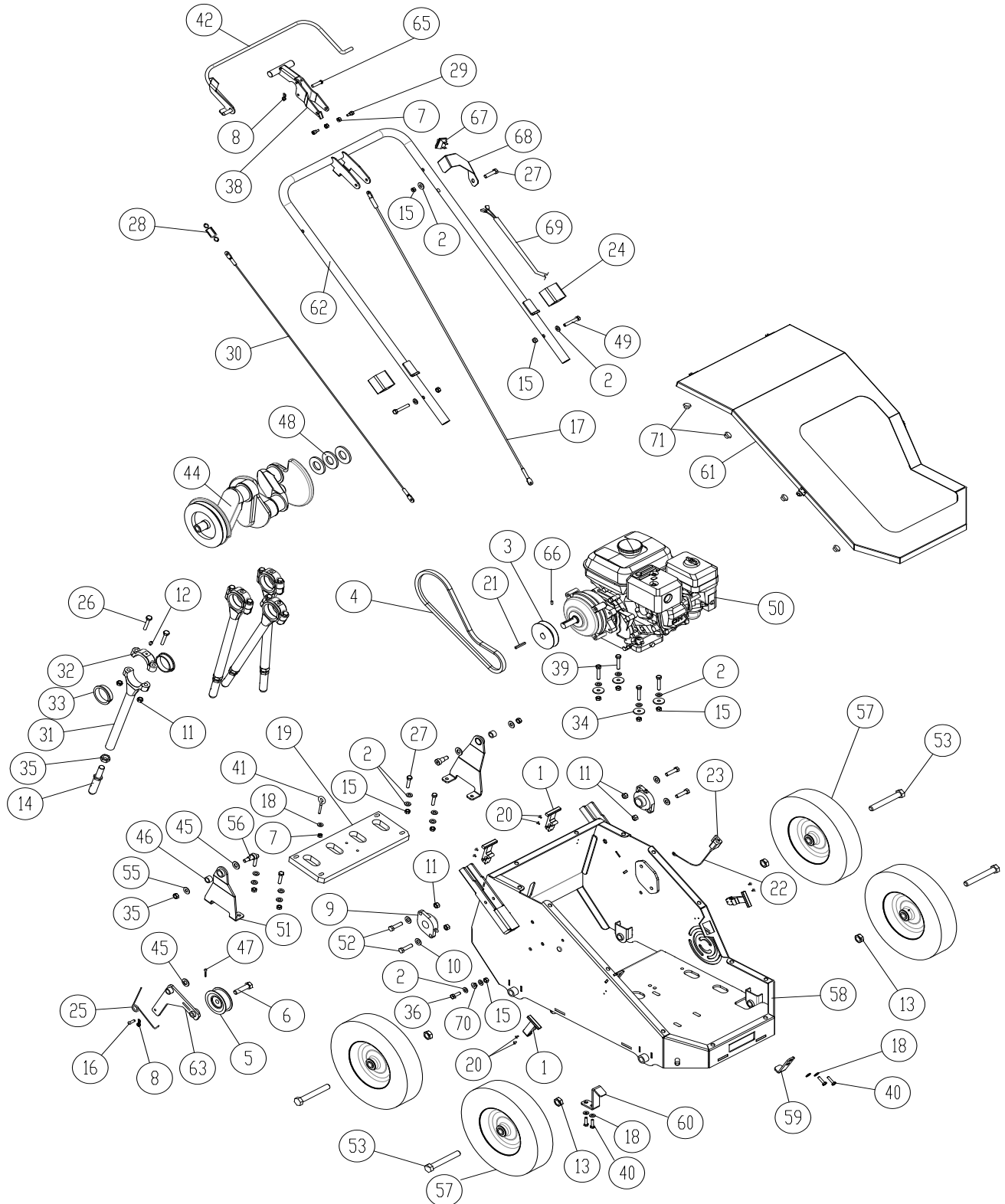



PL18 Owner's Manual

PL1800/H PARTS LIST

ITEM #	PART #	DESCRIPTION	PL1800H QTY	PL1800V QTY	ITEM #	PART #	DESCRIPTION	PL1800H QTY	PL1800V QTY
1	381003-01	RUBBER LATCH KIT	4	4	51	381632	RETRACTOR PLATE ARM	2	2
2	8171003	FLAT WASHER 5/16"	17	17	52	8041052	SCREWCAP 3/8"-16 X 1 1/2" HCS ZP	4	4
3	381018	ENGINE PULLEY 3.5"	1	1	53	8041151	SCREWCAP 5/8"-11 X 4 1/2" HCS ZP	4	4
4	381019	COGGED V-BELT B 35"	1	1	55	381757	WASHER 5/16" USS THRU-HARDENED ZINC YELLOW	2	2
5	350114	IDLER PULLEY 2.75" DIA	1	1	56	381758	SHOULDER BOLT 1/2" X 5/8"	2	2
6	8041052	SCREWCAP 3/8" - 16 x 1 1/2" GR 5 ZP	1	1	57	381768	WHEEL 12" SEMI-PNEUMATIC W/ 5/8" BEARING HUB	4	4
7	8160001	NYLOCK NUT 1/4"- 20 UNC	3	3	58	381769	400 SERIES FRAME	1	1
8	371275	1/4" RUE RING	2	2	59	381769-09	UPPER BELT TENSIONER BRACKET	1	1
9	381042	CARTRIDGE BEARING 1" DIA	2	2	60	381769-10	LOWER BELT TENSIONER BRACKET	1	1
10	8171004	3/8" FLAT WASHER	4	4	61	381770-WA	COVER WA PL18	1	1
11	8160003	NUTLOCK 3/8-16	19	19	62	381771	400 SERIES HANDLE	1	1
12	610363	ZERK FITTING GREASE	4	4	63	381772	CLUTCH ARM	1	1
13	381110	NUT JAM 5/8"-11 2 WAY LOCKNUT ZP	4	4	64	381777	PL1800 DECAL KIT	1	1
14	381057	TINE 5/8" DIA	4	4	65	381345	PIN CLEVIS 1/4" X 1 1/8" ZP	1	1
15	8160002	NUTLOCK 5/16"-18	13	13	66	8084106	SCREW SET 5/16"-18 X 5/16" TORQUE TO 22-24 FT-LBS.	1	1
16	381077	CLEVIS PIN 1/4" X 3/4"	1	1	67	500281	SWITCH LKG RKR	1	1
17	381089	RETRACTOR PLATE CABLE	1	1	68	430141	BRACKET MOUNT SWITCH	1	1
18	8171002	WASHER 1/4" FLAT	5	5	69	360316	HARNESS WIRE 60"	1	1
19	381097	400 SERIES RETRACTOR PLATE	1	1	70	350346	NUT 5/16" - 18 SER HEX WSHR FLNG ZP	1	1
20	381115	STAINLESS RIVET 1/8" X 1/4"	8	8	71	380224	RUBBER BUMPER PUSH IN	14	14
21	9201080	KEY 3/15" SQ X 1 1/4	1	1					
22	380227	WIRE HARNESS PL HOOD SWITCH	1	1					
23	840058	SWITCH INTERLOCK	1	1					
24	381135	HANDLE LOCK SLEEVE	2	2					
25	381138	CLUTCH TORSION SPRING	1	1					
26	8041054	SCREWCAP 3/8"-16 X 2"	8	8					
27	8041030	SCREWCAP 5/16"-18 X 1 1/2"	5	5					
28	381157	EXTENSION SPRING 3/4" X 1" - 3"	1	1					
29	381158	SOCKET HEAD SHOULDER BOLT 5/16" X 1/4"	2	2					
30	381168	CLUTCH CABLE 37"	1	1					
31	381175	TINE ROD	4	4					
32	381176	TINE ROD CAP	4	4					
33	380213	JOURNAL BEARING 2"	8	8					
34	8172020	FENDER WASHER 5/16"	4	4					
35	8143007	NUT JAM 5/8"-11 ZP	4	4					
36	8041028	SCREWCAP 5/16"-18 X 1" HCS ZP	1	1					
37	381198	RETRACTOR PLATE LATCH	1	1					
38	381201	RETRACTOR HANDLE	1	1					
39	8041031	SCREWCAP 5/16"-18 X 1 3/4" HCS ZP	4	4					
40	8041004	SCREWCAP 1/4"-20 X 3/4" GR 5 HCS ZP	4	4					
41	381272	EYEBOLT 1/4" - 20	1	1					
42	381288	400 SERIES CLUTCH LEVER	1	1					
44	381296	4 TINE CRANK	1	1					
45	8171006	WASHER 1/2" FLAT	3	3					
46	381512	BUSHING 1/2" ID X 3/4" OD X 1/2"	2	2					
47	8197031	COTTER PIN 1/8" X 1"	1	1					
48	362205	MACHINERY BUSHING 1" X 1 1/2" X 14 GA	3	3					
49	8041032	SCREWCAP 5/16"-18 X 2" HCS ZP	2	2					
50	360278	HONDA ENGINE GX120 W/GEARBOX	1	-					
	380229	BRIGGS VANGUARD ENGINE W/GEARBOX	-	1					