



Zoom®

Owner/Operator Manual

Manuel Du Propriétaire/Utilisateur

Models

915131 – 1334



GB ENGLISH

F FRANÇAIS

03770600 11/08
Printed in USA

TABLE OF CONTENTS

SAFETY	4	STORAGE	26
ASSEMBLY	10	TROUBLESHOOTING	26
CONTROLS AND FEATURES	12	SERVICE PARTS	28
OPERATION	13	ACCESSORIES	28
MAINTENANCE SCHEDULE	16	SPECIFICATIONS	29
SERVICE AND ADJUSTMENTS	18	WARRANTY	30

INTRODUCTION

NON-ENGLISH MANUALS



Manuals in languages other than English may be obtained from your Dealer. Visit your dealer or www.ariens.com for a list of languages available for your equipment.



Manuals printed in languages other than English are also available as a free download on our website:

<http://www.ariens.com>

MANUALES EN IDIOMAS DIFERENTES DEL INGLÉS



Puede obtener manuales en idiomas diferentes del inglés en su distribuidor. Visite a su distribuidor o vaya a www.ariens.com para obtener una lista de idiomas disponibles para su equipo.



También puede imprimir manuales en idiomas diferentes del inglés descargándolos gratuitamente de nuestra página Web:

<http://www.ariens.com>

Manuels non anglais



Des manuels dans différentes langues sont disponibles chez votre revendeur. Rendez-vous chez votre revendeur ou allez sur le site www.ariens.com pour consulter la liste des langues disponibles pour votre équipement.



Les manuels imprimés dans des langues différentes de l'anglais sont également disponibles en téléchargement gratuit sur notre site Web :

<http://www.ariens.com>

THE MANUAL

Before operation of unit, carefully and completely read your manuals. The contents will provide you with an understanding of safety instructions and controls during normal operation and maintenance.

All reference to left, right, front, or rear are given from operator seated in operation position and facing the direction of forward travel.

MODEL AND SERIAL NUMBERS

When ordering replacement parts or making service inquiries, know the Model and Serial numbers of your unit and engine.

Numbers are located on the product registration form in the unit literature package. They are printed on a serial number label, located on the frame of your unit under the seat (figure 1).



Unit Serial Number Label

Figure 1

- Record Unit Model and Serial numbers here.

- Record Engine Model and Serial numbers here.

PRODUCT REGISTRATION

The Ariens dealer must register the product at the time of purchase. Registering the product will help the company process warranty claims or contact you with the latest service information. All claims meeting requirements during the limited warranty period will be honored, whether or not the product registration card is returned. Keep a proof of purchase if you do not register your unit.

Customer Note: If the Dealer does not register your product, please fill out, sign and return the product registration card to Ariens or go to www.ariens.com on the internet

UNAUTHORIZED REPLACEMENT PARTS

Use only Ariens replacement parts. The replacement of any part on this unit with anything other than an Ariens authorized replacement part may adversely affect the performance, durability, and safety of this unit and may void the warranty. Ariens disclaims liability for any claims or damages, whether warranty, property damage, personal injury or death arising out of the use of unauthorized replacement parts.

NOTE: A complete Parts manual may be download from www.ariens.com on the internet

DELIVERY

Customer Note: If you have purchased this product without complete assembly and instruction by your retailer, it is your responsibility to:

- Read and understand all assembly instructions in this manual. If you do not understand or have difficulty following the instructions, contact your nearest Ariens Dealer for assistance.

NOTE: To locate your nearest Ariens Dealer, go to www.ariens.com on the internet.

Before Attempting to Operate Your Unit:

1. Make sure all assembly has been properly completed.
2. Understand all Safety Precautions provided in the manuals.
3. Review control functions and operation of the unit. Do not operate the unit unless all controls function as described in this manual.
4. Review recommended lubrication, maintenance and adjustments.
5. Review Limited Warranty Policy.
6. Fill out a product registration card and return the card to the Ariens Company or go to www.ariens.com.

DISCLAIMER

Ariens reserves the right to discontinue, change, and improve its products at any time without notice or obligation to the purchaser.

The descriptions and specifications contained in this manual were in effect at printing. Equipment described within this manual may be optional. Some illustrations may not be applicable to your unit.



WARNING: Improper assembly or adjustments can cause serious injury.

SAFETY



WARNING: This cutting machine is capable of amputating hands and feet and throwing objects. Failure to observe the safety instructions in the manuals and on decals could result in serious injury or death.

Slopes are a major factor related to loss-of-control and tip-over accidents. Operation on all slopes requires extra caution.

Tragic accidents can occur if the operator is not alert to the presence of children. Never assume that children will remain where you last saw them.

Gasoline is extremely flammable and the vapors are explosive, handle with care.

Disengage attachment, stop unit and engine, remove key, engage parking brake, and allow moving parts to stop before leaving operator's position.



CAUTION: POTENTIALLY HAZARDOUS SITUATION! If not avoided, **MAY RESULT** in minor or moderate injury. It may also be used to alert against unsafe practices.

NOTATIONS

NOTE: General reference information for proper operation and maintenance practices.

IMPORTANT: Specific procedures or information required to prevent damage to unit or attachment.

SAFETY DECALS AND LOCATIONS

ALWAYS replace missing or damaged Safety Decals. Refer to figure 2 for Safety Decal locations.

SAFETY ALERTS



Look for these symbols to point out important safety precautions. They mean:



- Attention!
- Personal Safety Is Involved!
- Become Alert!
- Obey The Message!

The safety alert symbol is used in decals and with this manual. Understand the safety message. It contains important information about personal safety.



WARNING: POTENTIALLY HAZARDOUS SITUATION! If not avoided, **COULD RESULT** in death or serious injury.



DANGER: IMMINENTLY HAZARDOUS SITUATION! If not avoided, **WILL RESULT** in death or serious injury.

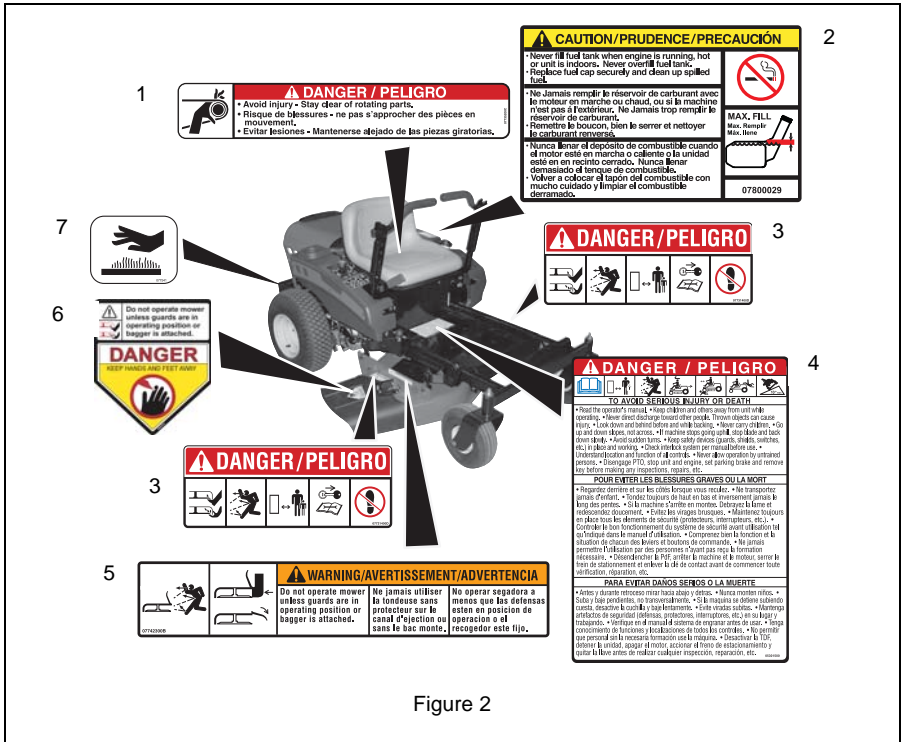

Figure 2

1.DANGER!



Avoid injury - Stay clear of rotating parts.

2.CAUTION



No smoking.



Do not overfill.
Fill fuel tank to below bottom of filler neck.

- Never fill fuel tank when engine is running, hot or unit is indoors. Never overfill fuel tank.
- Replace fuel cap securely and clean up spilled fuel.

3.DANGER!



Always keep feet and hands away from rotating parts.



Always stand clear of discharge area. Do not direct discharge toward other people.



Keep people away from unit while operating.



Shut off engine, remove key, and read manual before you adjust or repair unit.



NO STEP! Always keep feet away from rotating parts.

4.DANGER! TO AVOID SERIOUS INJURY OR DEATH



Read the operator's manual.



Keep children and others away from unit while operating.



Never direct discharge toward other people. Thrown objects can cause injury.



Look down and behind before and while backing.



Never carry children.



Go up and down slopes, not across.



DO NOT operate on slopes over 10°.

- If machine stops going uphill, stop blade and back down slowly.
- Avoid sudden turns.
- Keep safety devices (guards, shields, switches, etc.) in place and working.
- Check interlock system per manual before use.
- Understand location and function of all controls.
- Never allow operation by untrained persons.
- Disengage PTO, stop unit and engine, set parking brake and remove key before making any inspections, repairs, etc.

5.WARNING!



Always stand clear of discharge area.

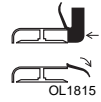

Do not operate mower unless bagger is attached or guards are in operating position.

6.DANGER!



Keep hands and feet away.



Do not operate mower unless guards are in operating position or bagger is attached.

7.HOT SURFACES!



DO NOT touch parts which are hot from operation. ALWAYS allow parts to cool.

EMISSION CONTROL SYSTEM CERTIFICATION LABEL

Tampering with emission controls and components by unauthorized personnel may result in severe fines or penalties. Emission controls and components can only be adjusted by EPA and/or CARB authorized service centers. Contact your Ariens Equipment Retailer concerning emission controls and component questions.

SAFETY RULES

If unit is to be used by someone other than original purchaser; loaned, rented or sold, ALWAYS provide this manual and any needed safety training before operation. Only the user can prevent and is responsible for accidents or injuries occurring to themselves, other people or property. Read, understand, and follow all safety practices in Owner/Operator Manual before assembling, using or working on this mower.

ALWAYS remove key from ignition and wire from spark plug before assembly, or working on this unit.

Inspect unit before each use for: missing or damaged decals and shields, correctly operating safety interlock system, and deterioration of grass catchers. Replace or repair as needed.

ALWAYS check overhead and side clearances carefully before operation.

ALWAYS be aware of traffic when crossing or operating along streets or curbs.

Keep children, people, and pets away. Be alert and shut off unit if anyone enters work area. Keep children under watchful care of a responsible adult.

NEVER allow children to operate or play on or near unit.

Keep area of operation clear of all toys, and debris. Thrown objects can cause injury.

Stay alert for hidden hazards, holes, and ruts.

Avoid uneven or rough terrain. DO NOT operate near drop-offs, ditches, or embankments. Unit can suddenly turn over if a wheel is over the edge of a cliff or ditch, or if an edge caves in.

Dust, fog, etc. can reduce vision and cause an accident. Operate unit only when there is good visibility and light.

Data indicates that operators, age 60 and above, are involved in a larger percentage of riding mower related injuries. These operators should evaluate their ability to operate the riding mower safely enough to protect themselves and others from serious injury.

Only trained adults may operate unit. Training includes being familiar with controls and actual operation.

NEVER operate unit after or during the use of medication, drugs or alcohol.

NEVER allow anyone to operate this unit when their alertness or coordination is impaired.

Wear adequate safety gear, sturdy shoes, and protective gloves.

DO NOT wear loose clothing or jewelry and tie back hair that may get caught in rotating parts.

Protect eyes, face and head from objects that may be thrown from unit. Wear appropriate hearing protection. Always wear safety goggles or safety glasses with side shields when operating mower.

Avoid sharp edges. Sharp edges can cut. Moving parts can cut off fingers or a hand.

ALWAYS keep hands and feet away from all rotating parts during operation. Rotating parts can cut off body parts.

ALWAYS keep hands away from all pinch points.

Start and operate unit only when seated in operator's position. Steering control levers must be in neutral, PTO disengaged and parking brake set when starting engine.

ALWAYS keep body and hands away from pin holes or nozzles which eject hydraulic fluid under pressure.

DO NOT touch unit parts which might be hot from operation. Allow parts to cool before attempting to maintain, adjust or service.

NEVER place your hands or any part of your body or clothing inside or near any moving part while unit is running.

NEVER direct discharge towards persons or property. Thrown objects may ricochet back towards operator. ALWAYS stand clear of the discharge area.

ALWAYS disengage attachment, stop unit and engine, remove key, engage parking brake, and allow moving parts to stop before leaving operator's position.

Use extreme caution on gravel surfaces.

Disengage PTO when attachment is not in use and when crossing gravel surfaces.

DO NOT operate unit if safety interlock system is damaged or disabled. Check safety interlock before each use.

ALWAYS remove key to prevent unauthorized use.

DO NOT operate at too fast a rate. Slow down before turning.

Stop engine before removing grass catcher or unclogging chute.

DO NOT mow on wet grass. Reduced traction could cause sliding.

DO NOT try to stabilize the machine by putting your foot on the ground.

Know the weight of loads. Limit loads to those you can safely control and the unit can safely handle.

ALWAYS keep protective structures, guards and panels in good repair, in place and securely fastened.

Do not operate without either entire grass catcher or the discharge guard in place.

DO NOT operate in reverse unless absolutely necessary. ALWAYS look down and behind before and while backing; especially for children.

Follow the manufacturer's recommendations for wheel weights or counterweights to improve stability when using attachments.

NEVER carry passengers—especially children—even with blades off.

Use extra care when approaching blind corners or objects that may obscure vision of hidden obstacles and children.

If you cannot back up a slope or you feel uneasy on it, do not mow it.

Mow up and down slopes, not across them.

Use slow speed on any slope. Tires may lose traction on slopes even though the brakes are functioning properly.

Keep all movements on the slope *slow* and *gradual*. DO NOT make sudden changes in speed or direction.

Use extra care while operating machines with grass catcher or other attachments. They can affect stability of the machine.

Avoid starting, stopping, or turning on a slope. If tires lose traction, disengage the blades and proceed slowly *straight* down the slope.

DO NOT operate on slopes over 10°.

DO NOT park on slopes unless necessary. If unit is parked on a slope, ALWAYS chock or block wheels and set parking brake.

DO NOT disengage or bypass transmission and coast downhill.

Tow only with a machine that has a hitch designed for towing. Do not attach towed equipment except at the hitch point.

Follow the manufacturer's recommendations for weight limits for towed equipment and towing on slopes.

Maximum Tongue weight: 30 lbs.

Maximum Trailer weight: 300 lbs.

Do not use hitch with bagger attached.

Do not use on steep hills or slopes.

Do not park on hills when trailer is attached.

Do not use with any ground engaging equipment.

NEVER allow children or others in or on towed equipment.

On slopes, the weight of the towed equipment may cause loss of traction and loss of control.

Travel slowly and allow extra distance to stop.

Use extra care when loading or unloading unit onto trailer or truck.

Secure unit chassis to transport vehicle.

NEVER secure from rods or linkages that could be damaged.

DO NOT transport machine while engine is running.

ALWAYS turn off power to attachment and shut off fuel when transporting unit.

Keep unit free of grass clippings, leaves, and other debris. Clean up oil or fuel spills.

This product is equipped with an internal combustion type engine. DO NOT use unit on or near any unimproved, forest-covered or brush covered land unless exhaust system is equipped with a spark arrester meeting applicable local, state or federal laws. A spark arrester, if it is used, must be maintained in effective working order by operator.

Fuel is highly flammable and its vapors are explosive. Handle with care. Use an approved fuel container.

NO smoking, NO sparks, NO flames. ALWAYS allow engine to cool before servicing.

NEVER fill fuel tank when engine is running or hot from operation.

NEVER fill or drain fuel tank indoors.

NEVER overfill fuel tank.

Replace fuel cap securely and clean up spilled fuel.

NEVER fill containers inside a vehicle or on a truck or trailer bed with a plastic liner. Always place containers on the ground away from your vehicle before filling.

When practical, remove gas-powered equipment from the truck or trailer and refuel it on the ground. If this is not possible, then refuel such equipment on a trailer with a portable container, rather than from a gasoline dispenser nozzle.

Keep the nozzle in contact with the rim of the fuel tank or container opening at all times until fueling is complete. Do not use a nozzle lock-open device.

If fuel is spilled on clothing, change clothing immediately.

Avoid Electric Shock. Objects contacting both battery terminals at the same time may result in injury and unit damage. DO NOT reverse battery connections.

Explosive Gases from battery can cause death or serious injury. Poisonous battery fluid contains sulfuric acid and its contact with skin, eyes or clothing can cause severe chemical burns.

NO flames, NO sparks, NO smoking near battery.

ALWAYS wear safety glasses and protective gear near battery. Use insulated tools.

DO NOT TIP battery beyond a 45° angle in any direction.

ALWAYS keep batteries out of reach of children.

Battery posts, terminals and related accessories contain lead and lead compounds, chemicals known to the State of California to cause cancer and reproductive harm. Wash hands after handling.

Reverse connections may result in sparks which can cause serious injury. Always connect positive (+) lead of charger to positive (+) terminal, and negative (-) lead to negative (-) terminal.

ALWAYS disconnect negative (-) cable FIRST and positive (+) cable SECOND. ALWAYS connect positive (+) cable FIRST, and negative (-) cable SECOND.

A frozen battery can explode and result in death or serious injury. DO NOT charge or jump start a battery containing frozen fluid. Thaw the battery before putting on a charger or jump starting.

ALWAYS keep protective structures, guards, and panels in good repair, in place and securely fastened. NEVER modify or remove safety devices.

DO NOT change engine governor settings or over-speed engine.

Fumes from engine exhaust can cause injury or death. DO NOT run engine in an enclosed area. Always provide good ventilation.

ALWAYS maintain unit in safe operating condition. Damaged or worn out muffler can cause fire or explosion.

Stop and inspect equipment if you strike an object or if there is an unusual vibration. Repair, if necessary, before restarting. Never make adjustments or repairs with the engine running.

Mower blades are sharp and can cut you. Wrap the blade(s) or wear gloves, and use extra caution when servicing them. NEVER weld or straighten mower blades.

Rotation of one blade may cause rotation of the other blades.

Check brake operation frequently. Adjust and service as required.

Keep all hardware properly tightened.

Stored energy in springs can cause injury.

Maintain or replace safety and instruction labels, as necessary.

Never store the machine or fuel container inside a building where there is an open flame, such as a water heater.

Shut off fuel (if provided) and allow engine to cool completely before storing in closed area or covering unit.

Clean grass and debris from unit, especially from around muffler and engine, to help prevent fires.

For extended storage, clean unit thoroughly. See Engine Manual for proper storage.

Use only attachments or accessories designed for your unit.

Check attachment components frequently. If worn or damaged, replace with manufacturer's recommended parts.

ASSEMBLY



WARNING: AVOID INJURY.
Read and understand the entire
Safety section before proceeding.

Tools Required

- Adjustable wrench
- Petroleum jelly or dielectric grease.

Unpack Unit

Remove unit and all other components from the shipping container. Engage transmission bypass lever (see *MOVING UNIT MANUALLY* on page 15). Push unit from container onto a level surface. Disengage transmission bypass lever.

Connect Battery

See *Battery Removal and Installation* on page 22 and perform steps 2 and 3 in the installation section.

Place Unit in Operating Position (Figure 3):

NOTE: The seat is shipped with the seat positioned as far back as possible.

1. Tip seat forward and adjust the seat as needed (see *TIPPING SEAT FORWARD* on page 18 and *SEAT ADJUSTMENT* on page 18).
2. Remove eccentric spacers and rotate steering levers to the operating position. Reinstall spacers. Do not tighten.
3. Adjust steering levers (see *ADJUSTING STEERING LEVERS* on page 23).

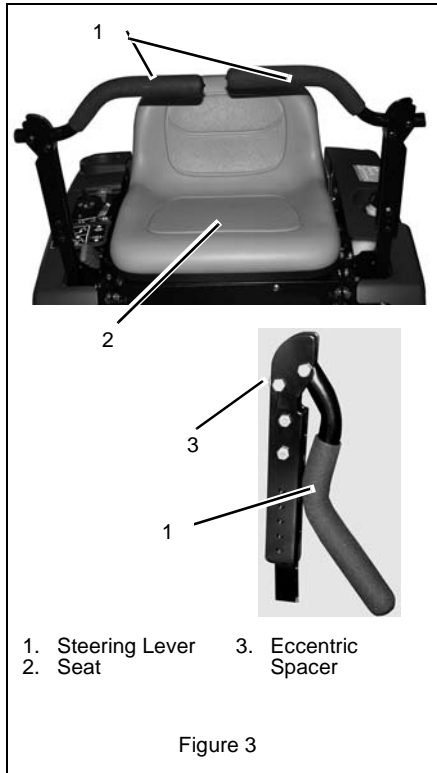

Check Engine Oil Level

Refer to Engine Manual.

Check Tire Pressure



CAUTION: Avoid injury! Explosive separation of tire and rim parts is possible when they are serviced incorrectly:

- Do not attempt to mount a tire without the proper equipment and experience to perform the job.
- Do not inflate the tires above the recommended pressure.
- Do not weld or heat a wheel and tire assembly. Heat can cause an increase in air pressure resulting in an explosion. Welding can structurally weaken or deform the wheel.
- Do not stand in front or over the tire assembly when inflating. Use a clip-on chuck and extension hose long enough to allow you to stand to one side.

See *SPECIFICATIONS* on page 29.

Level Mower Deck

See *LEVELLING AND ADJUSTING PITCH OF MOWER DECK* on page 20.

Fill Fuel Tank

See *FILLING FUEL TANK* on page 14.

Check Safety Interlock System



WARNING: Safety interlock failure and improper operation of unit can result in death or serious injury. Check system before each use to make sure it is functioning properly.

See *Safety Interlock System* on page 13.

Check function of all controls

See *OPERATION* on page 13.

CONTROLS AND FEATURES

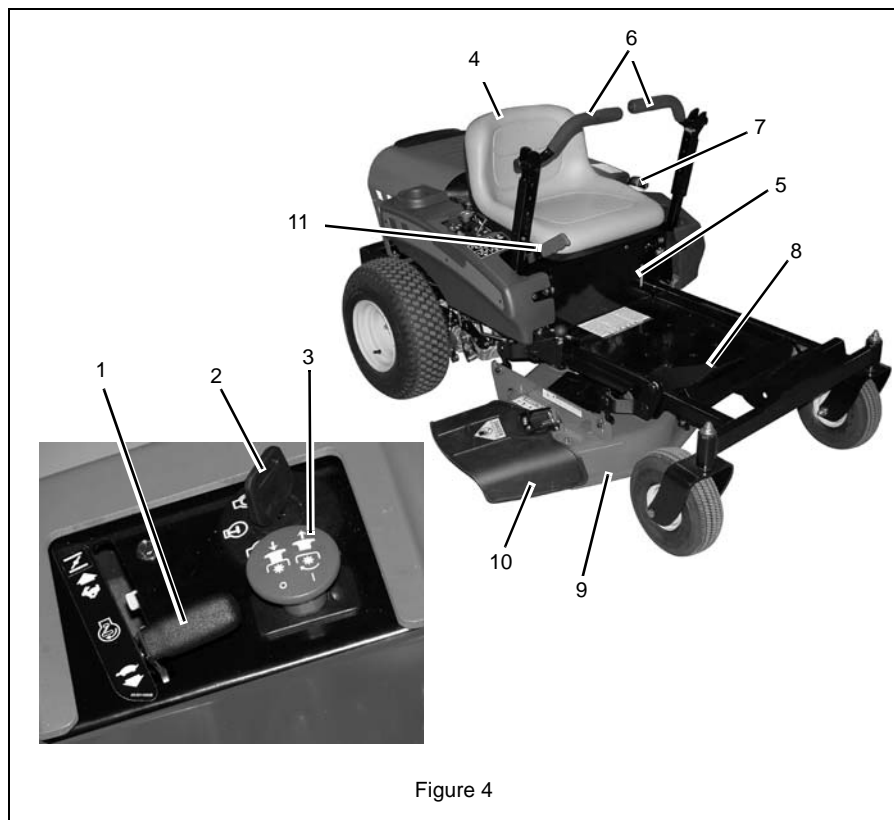

Figure 4

1. Throttle/Choke Lever
2. Ignition Switch
3. PTO Switch
4. Seat
5. Fuel Level

6. Steering Levers
7. Fuel Tank
8. Mower Lift Pedal
9. Mower Deck
10. Discharge Chute
11. Parking Brake

OPERATION



WARNING: AVOID INJURY.
Read and understand the entire *Safety* section before proceeding.

CONTROLS AND FEATURES

See figure 4 for all controls and features locations.

Safety Interlock System



WARNING: Safety interlock failure and improper operation of unit can result in death or serious injury. Check system before each use to make sure it is functioning properly.

Perform the following tests to ensure the safety interlock system is working properly. If the unit does not perform as stated contact your Ariens dealer for repairs.

Test	Steering Lever	PTO	Parking Brake	Engine
1	Neutral Position	Off	Engaged	Starts
2	Neutral Position	On	Engaged	Doesn't Start
3	Neutral Position	Off	Disengaged	Doesn't Start
4*	Out of Neutral Position	Off	Disengaged	Shuts Off
5*	Neutral Position	On	Engaged	Shuts Off

* Test with engine running.

+ Operator lifts off seat.

Ignition Switch

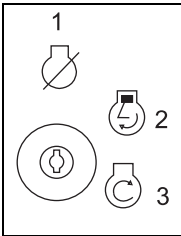

Operate ignition switch with a removable key. Ignition switch has three positions: Stop (1), Run (2), Start (3). See *STARTING AND SHUTTING OFF ENGINE* on page 14 for detailed instructions on how to start engine.

Parking Brake

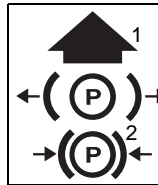

Engages (2) and disengages (1) parking brake.

Throttle/Choke Lever



Choke (1) – Use to start a cold engine.

Fast (2) – Increases engine speed.

Slow (3) – Decreases engine speed.

Power Take-Off (PTO) Switch

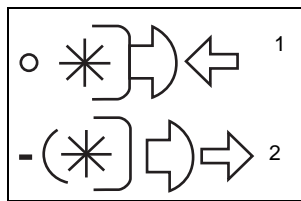

Engages (2) and disengages (1) mower blades.

Steering Levers

- Reverse (1) – Pull both steering levers backward.
- Forward (2) – Push both steering levers forward.
- Left (3) – Pull left steering lever back or push right steering lever forward or a combination of both.
- Right (4) – Pull right steering lever back or push left steering lever forward or a combination of both.

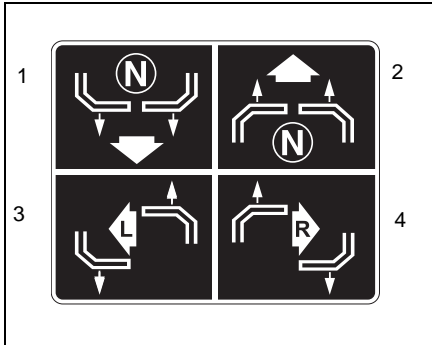

NOTE: To stop, return both steering levers to neutral.

NOTE: The steering levers must be in the neutral position to start the engine.

NOTE: The parking brake must be disengaged prior to moving the steering levers from the neutral position.

Mower Lift Pedal (Figure 5)

Raises and lowers mower deck.

Press mower lift pedal and install adjustment pin in the desired adjustment hole.

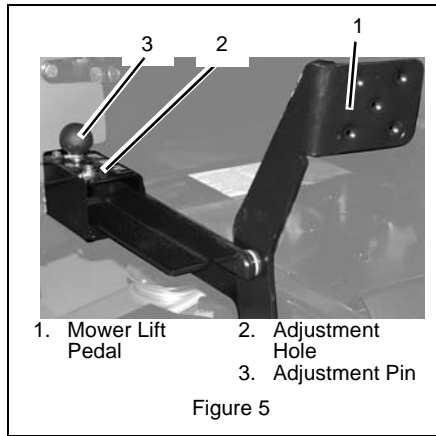

NOTE: The adjustment pin is used to set the height of the mower deck. See *SPECIFICATIONS* on page 29 for cutting height dimensions.

Fuel Level

Slot in seat plate shows the fuel level in the tank. Refill when level gets to bottom of slot.

FILLING FUEL TANK

1. Clean fuel cap and surrounding area to prevent dust, dirt, and debris from entering fuel tanks.
2. Remove fuel cap.

IMPORTANT: See Engine Manual for correct type and grade of fuel.

3. Fill fuel tank to below bottom of filler neck. See *SPECIFICATIONS* on page 29 for capacity of fuel tanks.
4. Replace fuel cap.

STOPPING IN AN EMERGENCY

Bring steering levers back to neutral, set parking brake, and turn off engine.

STARTING AND SHUTTING OFF ENGINE

Starting the Engine

NOTE: Disengage the PTO, place the steering levers in neutral, and engage the parking brake prior to starting the engine.

1. If the engine is cold, move the choke control to the On position. If the engine is warm or hot, do not use choke.

IMPORTANT: DO NOT operate starter for more than 10 seconds per minute as damage can occur.

2. Put the ignition key in the switch and turn it to the Start position.
3. As soon as the engine starts, release the key.
4. Move the choke control to the Off position from the Choke position. Wait until the engine is running smoothly before operation.

IMPORTANT: Let the engine warm up several seconds to several minutes depending on outside temperature.

Stopping the Engine

1. Stop unit.
2. Disengage PTO.
3. Set throttle lever to slow.
4. Turn ignition switch to off position and remove key.
5. Set parking brake.

OPERATING MOWER

1. Start engine.
2. Set throttle lever to fast.

IMPORTANT: Never engage PTO if mower is plugged with grass or other material.

3. Engage PTO to start mower blades. It will take 2–3 seconds for the blades to engage.

NOTE: The parking brake must be disengaged prior to moving the steering levers from the neutral lockout position.

4. Release parking brake.
5. Use steering levers to move the unit.
6. Disengage PTO to stop mower blades.

TRANSPORTING UNIT

ALWAYS shut off engine, set parking brake, remove key, and drain fuel when transporting unit on a truck or trailer. Tie unit down securely. Do not tie down by linkages, guards, cables or other parts that may be damaged.

FOR BEST PERFORMANCE

Cut grass when it is dry.
Keep mower blades sharp.
Keep mower deck properly leveled.
Do not set height of cut too low. For very tall grass, mow twice.
Do not travel too fast.
Mow with the engine set at full throttle.
When mulching, only remove 1/3 of grass length per cutting.
Discharge clippings into areas already cut.

Vary cutting pattern with each mowing.

Do not allow grass or debris to collect inside of mower deck. Clean after each use.

MOVING UNIT MANUALLY



WARNING: DO NOT disengage or bypass transmission and coast downhill.

Pull the bypass lever out and lock it in place, and then release the parking brake to push the unit by hand.

Push the lever in to drive the unit normally.

NOTE: There are two bypass levers; one on each side of the unit.

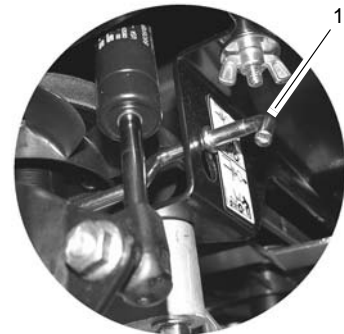

1. Bypass lever pulled out to push the unit by hand.
2. Bypass lever pushed in to drive the unit.

Figure 6

MAINTENANCE SCHEDULE



WARNING: AVOID INJURY. Read and understand the entire *Safety* section before proceeding.

IMPORTANT: Proper maintenance can prolong the life of unit. The following chart shows the recommended service schedule. Refer to the maintenance instructions in the Engine Manual for additional information.

NOTE: To have full access to the engine, the seat must be tipped forward (see *TIPPING SEAT FORWARD* on page 18) and the hood opened (see *MOWER DECK REMOVAL AND INSTALLATION* on page 18).

Interval	Task	Action
Each Use	Check Safety Interlock System	<p>WARNING: Safety interlock system failure and improper operation of unit can result in death or serious injury. Test this system each time the unit is operated. If this system does not function as described, do not operate until repairs are made (see <i>Safety Interlock System</i> on page 13).</p>
	Check Parking Brake	Engage parking brake and engage transmission bypass lever (see <i>MOVING UNIT MANUALLY</i> on page 15). Push unit. If unit rolls, contact your Ariens Dealer.
	Clean Unit	Clean engine, battery, seat, mower deck, etc. of all dirt and debris. Do not use solvents, hard cleaners, or abrasives.
	Check Tires	<p>NOTE: Protect painted surfaces with automotive type wax. See <i>SPECIFICATIONS</i> on page 29 for correct tire pressure.</p> <p> CAUTION: Avoid injury! Explosive separation of tire and rim parts is possible when they are serviced incorrectly:</p> <ul style="list-style-type: none"> • Do not attempt to mount a tire without the proper equipment and experience to perform the job. • Do not inflate the tires above the recommended pressure. • Do not weld or heat a wheel and tire assembly. Heat can cause an increase in air pressure resulting in an explosion. Welding can structurally weaken or deform the wheel. • Do not stand in front or over the tire assembly when inflating. Use a clip-on chuck and extension hose long enough to allow you to stand to one side.
	Check Mower Blades	Check for worn or damaged mower blades (see <i>SHARPENING MOWER BLADE</i> on page 21).

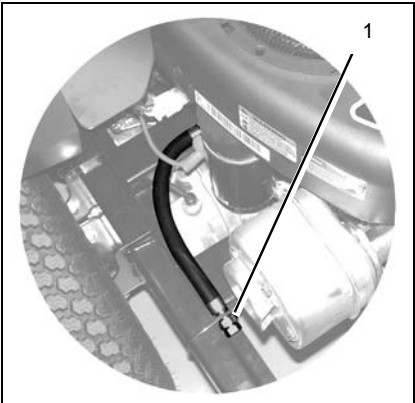
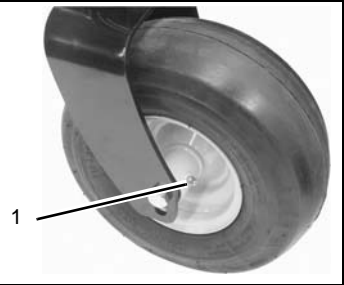
Interval	Task	Action
Each Use	Follow Engine Manual Maintenance Schedule	<p>Perform scheduled engine maintenance. Refer to Engine Manual for detailed instructions.</p> <p>NOTE: To drain the oil, use the oil drain petcock (1) supplied with unit, not the drain plug that is shown in the Engine Manual.</p> 
25 Hours or Every Season	Check Battery Lubricate Unit	<p>Keep battery and battery terminals clean (see <i>Cleaning Battery and Battery Cables</i> on page 22).</p> <p>Apply grease to zerk (1) on each front wheel</p> 
50 Hours or Every Season	Check Fasteners	<p>Check mower blade mounting hardware and all other fasteners. Replace fasteners that are missing or damaged. Tighten all nuts and bolts to the correct torque value.</p>
100 Hours or Every Season	Check All Belts	<p>Replace worn or deteriorated belts.</p> <ul style="list-style-type: none"> • Check hydrostatic belt (see <i>REPLACING HYDROSTATIC BELT</i> on page 25 for hydrostatic belt location). • Check PTO belt (see <i>REPLACING PTO BELT</i> on page 24 for PTO belt location).

SERVICE AND ADJUSTMENTS



WARNING: AVOID INJURY.
Read and understand the entire
Safety section before proceeding.

TIPPING SEAT FORWARD

Put steering levers up and tip seat forward (figure 7).

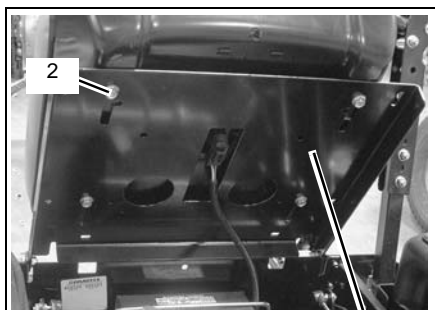

1. Seat Tipped Forward
2. Mounting Hardware

Figure 7

SEAT ADJUSTMENT

1. Tip the seat forward.
2. Loosen mounting hardware and slide seat forward or backward to desired position. Tighten mounting hardware (figure 7).
3. Tip seat back.

MOWER DECK REMOVAL AND INSTALLATION

Remove (Figure 9)

1. Remove PTO belt from the engine drive pulley (see *REPLACING PTO BELT* on page 24).
2. Disconnect pto actuator cable from the cable anchor and deck idler arm.



1. Cable Anchor
2. PTO Actuator Cable
3. Idler Arm

Figure 8

NOTE: Perform steps 3 and 4 for the right and left side of unit.

3. Disconnect drag link from the front deck bracket.
4. Disconnect front and rear trunnions from the lift arms.
5. Slide mower deck out from under unit.

Install (Figure 9)

1. Slide mower deck under unit.

NOTE: Perform step 2 and 3 for the right and left side of unit.

2. Connect drag link to front deck bracket.
3. Connect front and rear trunnions to lift arms.
4. Connect the pto actuator cable to the deck idler arm and cable anchor.

NOTE: Make sure the cable is taut, but not tight. The cable needs a slight amount of slack for the pulley brake to work correctly.

5. Install PTO belt on the engine drive pulley (see *REPLACING PTO BELT* on page 24).
6. Level and adjust pitch of mower deck (see *LEVELLING AND ADJUSTING PITCH OF MOWER DECK* on page 20).

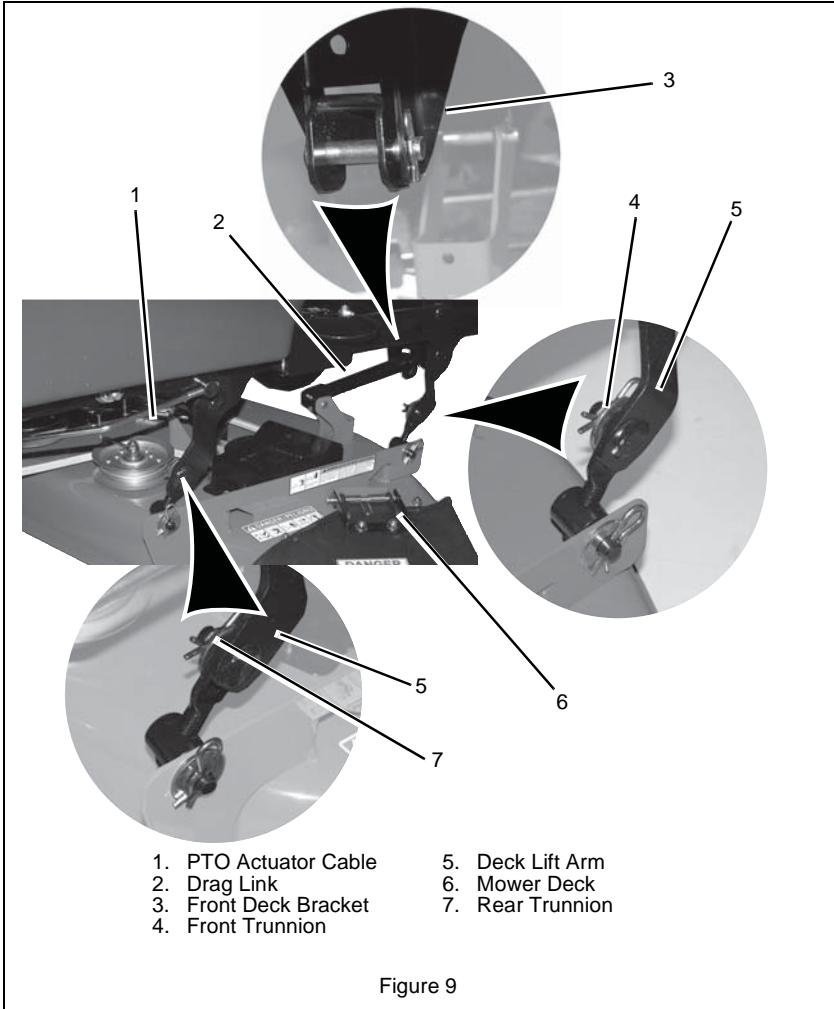

LEVELLING AND ADJUSTING PITCH OF MOWER DECK

NOTE: Adjust on a level surface, with the tires inflated to the correct air pressure (see *SPECIFICATIONS* on page 29).

Three measurements are required to level and adjust the pitch of the mower deck.

1. The distance from the mower blades to the ground.
2. The forward pitch of the mower blades.
3. The pitch of the mower blades from side-to-side.

The Distance From The Mower Blades To The Ground (Figure 10):

- In the lowest cutting position should be 1 in. \pm 1/4 in. (2.54 cm \pm 0.64 cm).
- In the highest cutting position should be 4 in. \pm 1/4 in. (10.2 cm \pm 0.64 cm).

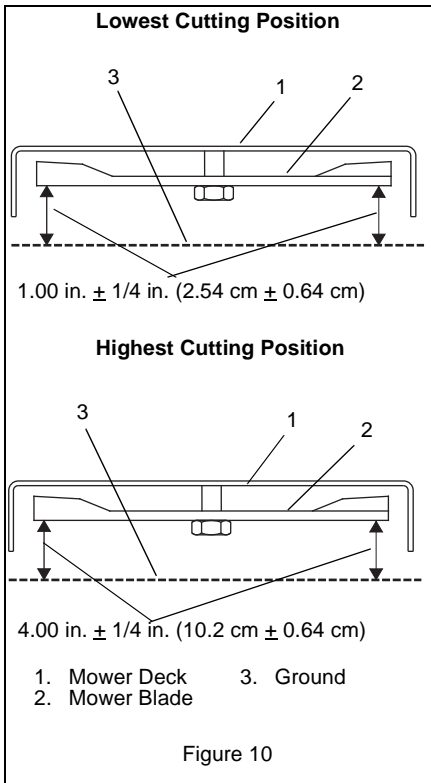

The Forward Pitch Of The Mower Blades (Figure 11):

- Should be 0.0 in. (0.0 mm) to 1/4 in. (6.35 mm) pitched forward.

NOTE: This measurement must be taken when the mower blade ends point forward.

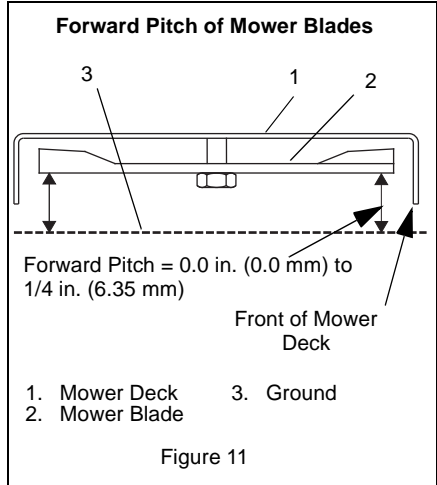

The Pitch Of The Mower Blades From Side-To-Side (Figure 12):

- Should be within 1/4 in. (6.35 mm) as measured on each side of the mower deck.

NOTE: This measurement must be taken when the mower blade ends point left and right.

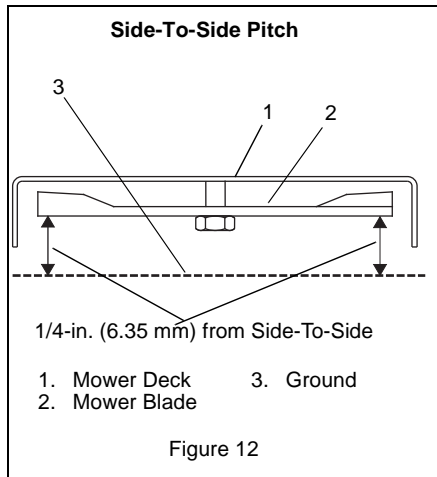

Adjusting The Mower Deck To Adjust Mower Blade Height And Pitch (Figure 13):

NOTE: Adjusting the mower deck will adjust the height and pitch of the mower blades.

1. Adjust the trunnions first and re-take the three measurements required to level and adjust the pitch of the mower deck. These measurements are:
 - a. The distance from the mower blades to the ground.
 - b. The forward pitch of the mower blades.
 - c. The pitch of the mower blades from side-to-side.
2. Repeat step 1 as needed until all three measurements are within the tolerances specified.

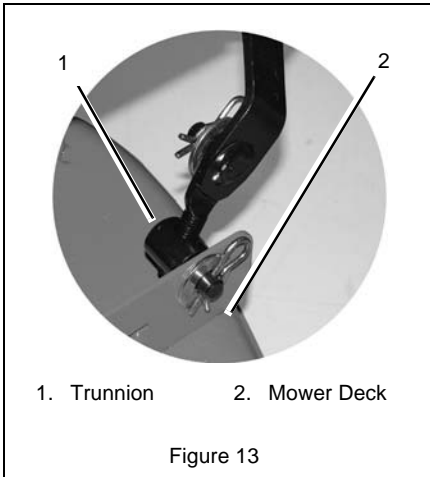

Figure 13

REPLACING MOWER BLADE

Remove (Figure 14)



CAUTION: Mower blades are sharp and can cut you. Wrap the blades or wear gloves, and use extra caution when servicing them.

1. Block mower blades to prevent rotation.
2. Remove mounting hardware and mower blades from spindles.

Install (Figure 14)

1. Install mower blades on spindles with mounting hardware.
2. Torque 5/8-inch nut to 92 to 130 lbf-ft (125 to 176 N•m).

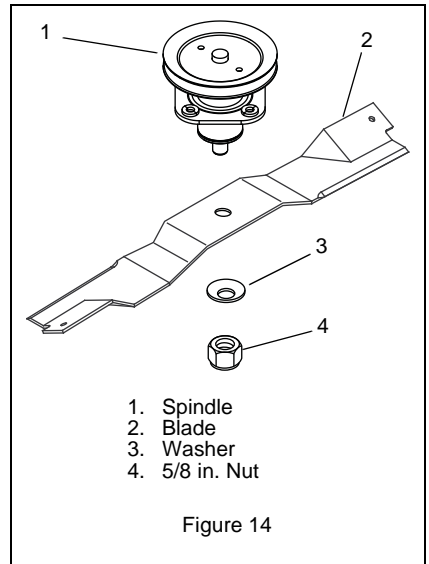

Figure 14

SHARPENING MOWER BLADE



CAUTION: DO NOT sharpen mower blade while on unit. An unbalanced mower blade will cause excessive vibration and eventual damage to unit. Check mower blade balance prior to reinstalling mower blades. NEVER weld or straighten mower blades.

1. Remove mower blade from unit (see *REPLACING MOWER BLADE* on page 21).

Ariens recommends having mower blades sharpened by a professional. Contact your Ariens dealer.

Discard mower blade if (figure 15):

- more than 1/2 in. (1.27 cm) of metal is removed.
- the air lift erosion area is eroded.
- the mower blade is bent or broken.

Do not change angle of cutting edge or round the corner at the end of mower blade.

2. Sharpen mower blade by removing an equal amount of material from each end of mower blade.

3. Check mower blade balance by sliding mower blade on an unthreaded bolt. If blade is balanced, it should remain in a horizontal position. If either end of mower blade moves downward, sharpen the heavy end until mower blade is balanced.
4. Install mower blade on unit (see *REPLACING MOWER BLADE* on page 21).

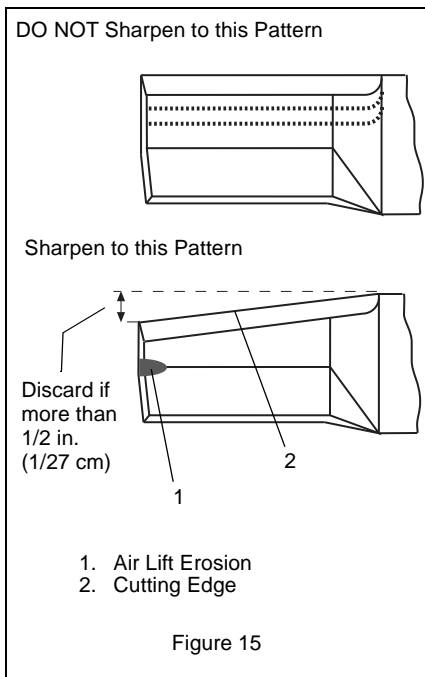

SERVICING THE BATTERY

NOTE: Unit comes equipped with a maintenance-free battery that requires no regular maintenance except cleaning the terminals.



WARNING: Battery posts, terminals and related accessories contain lead and lead compounds, chemicals known to the State of California to cause cancer and reproductive harm. Wash hands after handling.

Battery Removal and Installation

Remove (Figure 16)

1. Tip seat forward (see *TIPPING SEAT FORWARD* on page 18).
2. Disconnect negative (-) cable first, then positive (+) cable.
3. Remove battery hold-down bracket and battery from unit.

Install (Figure 16)

1. Install battery on the unit with battery hold-down bracket.
2. Connect positive (+) cable first, then negative (-) cable.
3. Apply petroleum jelly or dielectric grease to battery cable ends and terminals.
4. Tip seat back (see *TIPPING SEAT FORWARD* on page 18).

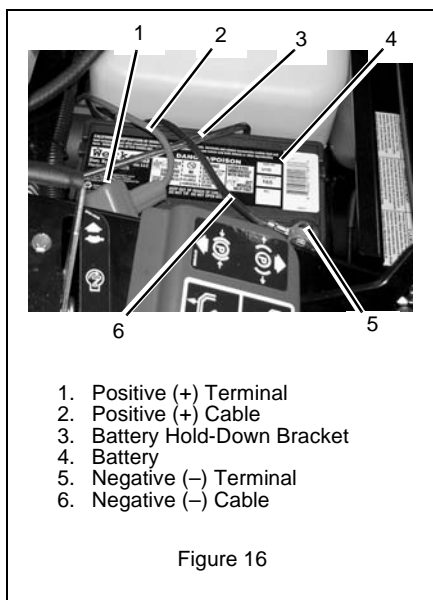

Cleaning Battery and Battery Cables (Figure 16)

1. Tip seat forward (see *TIPPING SEAT FORWARD* on page 18).
2. Disconnect negative (-) cable first, then positive (+) cable.
3. Clean battery cable ends, negative (-) terminal, and positive (+) terminal with a wire brush and rinse with a weak baking soda solution.
4. Connect positive (+) cable first, then negative (-) cable.
5. Apply petroleum jelly or dielectric grease to battery cable ends and terminals.

6. Tip seat back (see *TIPPING SEAT FORWARD* on page 18).

Charging the Battery (Figure 16)



WARNING: FROZEN BATTERIES CAN EXPLODE and result in death or serious injury. **DO NOT** charge a frozen battery. Let the battery thaw before charging.

Follow First Aid directions for contact with battery fluid.

- External Contact: Flush with water.
- Eyes: Flush with water for at least 15 minutes and get medical attention immediately!
- Internal Contact: Drink large quantities of water. Follow with Milk of Magnesia, beaten egg or vegetable oil. Get medical attention immediately!
- In case of internal contact, **DO NOT** induce vomiting!

IMPORTANT: **DO NOT** fast charge. Charging at a higher rate will damage or destroy battery.

IMPORTANT: **ALWAYS** follow information provided on battery and battery charger. Contact battery and battery charger manufacturers' for detailed instructions.

1. Remove battery from unit (see *Battery Removal and Installation* on page 22).
2. Place battery in a well-ventilated area.
3. Connect positive (+) lead of charger to positive (+) terminal, and negative (-) lead of charger to negative (-) terminal.
4. Charge battery according to battery charger and battery manufacturers' instructions.
5. Install battery on unit (see *Battery Removal and Installation* on page 22).

Jump-Starting

Ariens does not recommend jump-starting your unit. Jump-starting can damage engine and electrical system components. See your engine manual for more detailed information.

ADJUSTING STEERING LEVERS

Adjusting Steering Lever Height (Figure 17)

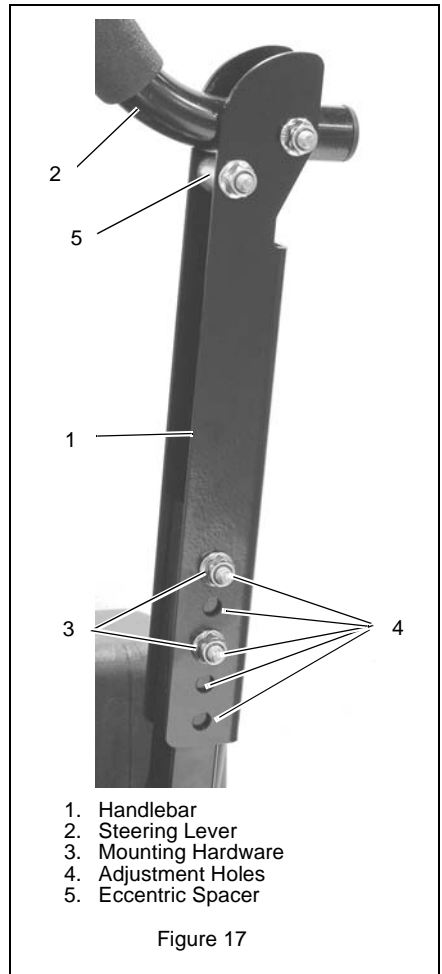

Figure 17

NOTE: Perform steps 1 and 2 for both steering levers.

1. Remove mounting hardware and move handlebar up or down until the steering levers are at the appropriate height.
2. Install mounting hardware.

NOTE: Align handlebars by adjusting eccentric spacer until the height of handlebars are the same.

Forward Speed Adjustment

(Figure 18)

NOTE: Reverse speed cannot be adjusted. If unit tracks excessively left or right in reverse, see your Dealer for repair.

IMPORTANT: The unit should track within 2 feet (0.61 m) of a straight line for 30 feet (9.14 m).

The travel of the steering levers may need adjustment if the unit turns to the right or left when both steering levers are pushed as far forward as possible.

NOTE: The side the unit turns toward indicates that the wheel on that side is turning slower than the other wheel. Either the wheel that is turning faster needs to slow down or the wheel that is turning slower needs to speed up to allow the unit to travel in a straight line.

1. Determine which way the unit turns.
2. Loosen jam nut on the adjustment bolt.
3. Adjust speed by:
 - Turning adjustment bolt clockwise to decrease steering lever travel.
 - Turning adjustment bolt counterclockwise to increase steering lever travel.
4. Tighten the jam nut.

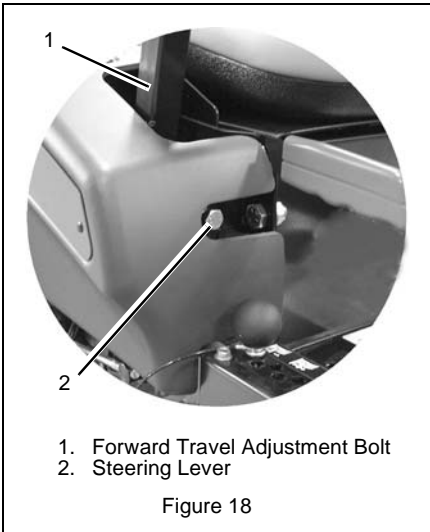

REPLACING PTO BELT

Remove (Figure 19)

1. Lower mower deck to the ground.
2. Remove belt covers from mower deck.



CAUTION: Use care when releasing idler spring tension. Keep body parts well away from idler when performing this operation.

3. Disconnect the pto actuator cable from the deck idler arm.
4. Pull idler arm towards outside of unit until tension is removed from PTO belt.
5. Remove PTO belt from left mower deck pulley.
6. Slowly release idler arm until tension is removed from idler spring.
7. Remove PTO belt from mower deck and engine drive pulley.

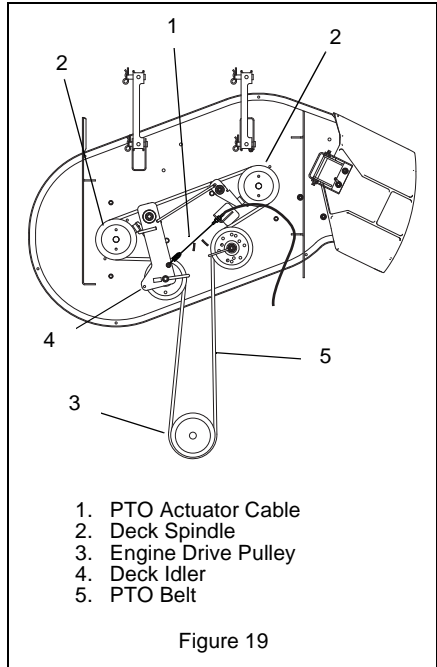

Install (Figure 19)

NOTE: Do not install PTO belt on left mower deck pulley in step 1.

1. Install PTO belt on engine drive pulley and mower deck.
2. Pull idler arm towards outside of unit until PTO belt can be routed around left mower deck pulley.
3. Slowly release idler arm until idler pulley rests firmly against PTO belt.
4. Connect the pto actuator cable to the deck idler arm.
5. Install belt covers on mower deck.

REPLACING HYDROSTATIC BELT

Remove (Figure 20)

1. Remove PTO belt (see *REPLACING PTO BELT* on page 24).



CAUTION: Use care when releasing idler spring tension. Keep body parts well away from idler when performing this operation.

2. Disconnect idler spring.
3. Remove hydrostatic belt from hydrostatic transmission pulleys, pulley, electric clutch, and idler.

Install (Figure 20)

1. Install hydrostatic belt on idler, electric clutch, pulley, and hydrostatic transmission pulleys.
2. Connect idler spring.
3. Install PTO belt (see *REPLACING PTO BELT* on page 24).

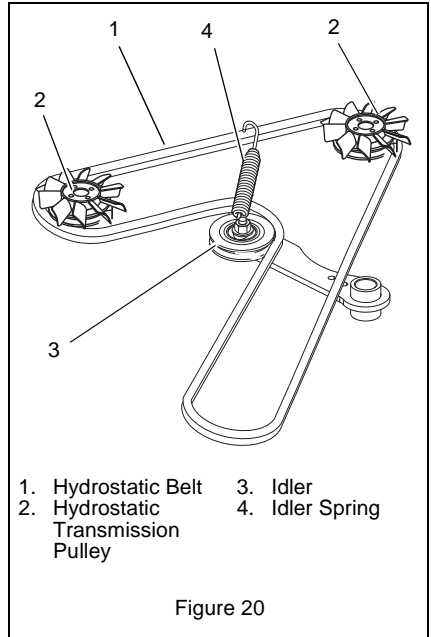

STORAGE

Short Term Storage

IMPORTANT: NEVER clean unit with high-pressure water or store unit outdoors.

Remove all dirt, grease, leaves, etc. Store in a clean dry area.

Inspect unit for signs of wear or damage. Ensure all fasteners are properly tightened.

Long Term Storage

Follow all instructions under *Short Term Storage*.

Remove and fully charge battery. Store in a clean dry area.

Drain fuel from fuel tank.

Refer to Engine Manual for the proper engine storage procedures.

Touch up all scratched or chipped paint surfaces.

Fuel System

Gasoline left in the fuel system for extended periods without a stabilizer will deteriorate, resulting in gum deposits in the system. These deposits can damage the carburetor and the fuel hoses, filter and tank. Prevent deposits from forming in the fuel system during storage by adding a quality fuel stabilizer to the fuel. Follow the recommended mix ratio found on the fuel stabilizer container.

To treat the fuel system for storage:

1. Add fuel stabilizer (Ariens part number 00592900) according to manufacturers's instructions.
2. Run engine for at least 10 minutes after adding stabilizer to allow it to reach the carburetor.

NEVER store the engine with fuel in the fuel tank inside of a building with potential sources of ignition.

TROUBLESHOOTING

PROBLEM	PROBABLE CAUSE	CORRECTION
Engine will not crank/start.	<ol style="list-style-type: none"> 1. Safety interlock system is not engaged or is faulty. 2. Fuel tank empty. 3. Discharged battery. 4. Poor connection between battery and battery cables. 5. Spark plug wire(s) loose or spark plug(s) faulty. 6. Faulty electrical system. 7. Faulty engine. 	<ol style="list-style-type: none"> 1. Check safety interlock system (see <i>Safety Interlock System</i> on page 13). 2. Fill fuel tank (see <i>FILLING FUEL TANK</i> on page 14). 3. Charge battery (see <i>Charging the Battery</i> on page 23). 4. Tighten battery cables and/or clean battery and battery cables (see <i>Cleaning Battery and Battery Cables</i> on page 22). 5. Connect spark plug wire(s) or replace spark plug(s). Refer to Engine Manual for detailed instructions. 6. Contact your Ariens Dealer. 7. Contact your Ariens Dealer.
Engine runs rough.	<ol style="list-style-type: none"> 1. Choke engaged. 2. Air filter cartridge plugged. 3. Faulty engine. 	<ol style="list-style-type: none"> 1. Disengage choke. 2. Clean or replace air filter cartridge. Refer to Engine Manual for detailed instructions. 3. Contact your Ariens Dealer.

PROBLEM	PROBABLE CAUSE	CORRECTION
Unit does not move with engine running when using steering levers.	<ol style="list-style-type: none"> 1. The transmission bypass lever is engaged. 2. Faulty hydrostatic belt. 3. Faulty transmission. 	<ol style="list-style-type: none"> 1. Disengage transmission bypass lever (see <i>MOVING UNIT MANUALLY</i> on page 15). 2. Replace hydrostatic belt (see <i>REPLACING HYDROSTATIC BELT</i> on page 25). 3. Contact your Ariens Dealer.
PTO or mower blades do not engage or shut off.	<ol style="list-style-type: none"> 1. Operator presence switch not depressed. 2. Faulty operator presence switch. 3. Clutch actuator is loose or disconnected. 4. Faulty PTO belt. 5. Faulty PTO switch, wires, connectors, or clutch. 	<ol style="list-style-type: none"> 1. Depress operator presence switch by sitting on seat. 2. Contact your Ariens Dealer. 3. Connect wiring to pto actuator. 4. Properly connect pto actuator cable to the deck cable anchor or to deck idler arm. 5. Replace PTO belt (see <i>REPLACING PTO BELT</i> on page 24). 6. Contact your Ariens Dealer.
Engine overheats.	<ol style="list-style-type: none"> 1. Engine oil level low. 2. Cooling system plugged. 3. Faulty engine. 	<ol style="list-style-type: none"> 1. Add engine oil. Refer to Engine Manual for detailed instructions. 2. Clean cooling system. Refer to Engine Manual for detailed instructions. 3. Contact your Ariens Dealer.
Unit moves with engine off and parking brake engaged.	<ol style="list-style-type: none"> 1. The parking brake needs adjustment. 2. Faulty parking brake. 	<ol style="list-style-type: none"> 1. Contact your Ariens Dealer. 2. Contact your Ariens Dealer.
Unit does not travel in a straight line.	<ol style="list-style-type: none"> 1. Incorrect tire pressure. 2. Steering levers need adjustment. 3. Hydrostatic transmission and/or linkage needs adjustment. 	<ol style="list-style-type: none"> 1. Check tire pressure (see <i>SPECIFICATIONS</i> on page 29). 2. Adjust steering levers (see <i>Forward Speed Adjustment</i> on page 24) 3. Contact your Ariens Dealer.
Unit creeps with steering levers in neutral position.	<ol style="list-style-type: none"> 1. Hydrostatic transmission and/or linkage needs adjustment. 	<ol style="list-style-type: none"> 1. Contact your Ariens Dealer.
Poor cutting quality.	<ol style="list-style-type: none"> 1. Mower deck not level or mower pitch is incorrect. 2. Dull or faulty mower blades. 	<ol style="list-style-type: none"> 1. Level and adjust pitch of mower deck (see <i>LEVELLING AND ADJUSTING PITCH OF MOWER DECK</i> on page 20). 2. Sharpen mower blades (see <i>SHARPENING MOWER BLADE</i> on page 21) or replace mower blades (see <i>REPLACING MOWER BLADE</i> on page 21).

SERVICE PARTS

Be sure to always use genuine Ariens parts to keep your unit running like new.

Part No.	Qty	Description
51559900	1	Spindle Assembly
07100801	1	Front Wheel
07200116	1	HA Wrapped Belt - Deck
07200010	1	HA Raw Laminated Belt - Hydraulic Drive
03746500	1	34-Inch Mower Blade
03797300	1	34-Inch Mulching Blade

ACCESSORIES

See your authorized Ariens dealer to add these optional accessories to your unit.

Part No.	Qty	Description
71503300	1	36-Inch Roller
71503400	1	48-Inch Dethatcher
71503600	1	Spreader
71508200	1	48-Inch Aerator
71510500	1	Steering Lever Extender
71510800	1	34-Inch Mulch Kit
71510900	1	Trailer Hitch Kit
81503100	1	34-Inch Non-Powered Bagger

SPECIFICATIONS

Model Number	915131
Model	Zoom 1334
Engine	
Type	Briggs & Stratton IC
Engine Displacement in. ³ (cc)	21 (344)
Governed RPM (May be different from maximum RPM)	3600 + 0 3600 – 100
Speed	
Forward Max. – m.p.h (km/h)	6.0 (9.6)
Reverse Max. – m.p.h (km/h)	3 (4.8)
Turning Radius	Zero
Brakes	Internal Transmission
Electrical	
Starter	Electric
Battery	12V Maintenance Free SLI U1B 165
PTO (Power Take-Off)	Cable Actuator
Fuel	
Fuel Type	Refer to Engine Manual
Fuel Tank Capacity – gal. (L)	2.5 (9.5)
Transmission	Hydrostatic Drive
Size and Weight	
Length – in. (cm)	65 (165.1)
Width – in. (cm)	45 (114.3)
Weight – lbs (kg)	420 (190.5)
Height – in. (cm)	40 (102)
Tires	
Front Tire Size – in.	4 x 11
Rear Tire Size – in.	18 x 6.5 x 8
Front Tire Pressure – psi (kPa)	46 (317)
Rear Tire Pressure – psi (kPa)	12 (82.7)
Mower Deck	
Cutting Height – in. (cm)	1.0 – 4.0 (2.5 – 10.2)
Cutting width – in. (cm)	34 (86)
Max. Towing Capacity – lbs (kg)	300 (136)
Max. Tongue Weight – lbs (kg)	30 (13.6)



Two-Year Limited Lawn and Garden Consumer Ride-On Warranty

Ariens Company (Ariens) warrants to the **original purchaser** that Ariens and Gravely brand consumer products manufactured and sold by Ariens after December 31, 2007 will be free from defects in material and workmanship for a period of two years after the date of purchase. An authorized Ariens dealer (Ariens brand products) or Gravely dealer (Gravely brand products) will repair any defect in material or workmanship, and repair or replace any defective part, subject to the conditions, limitations and exclusions set forth herein. Such repair or replacement will be free of charge (labor and parts) to the original purchaser except as noted below.

Five-Year Limited Warranty on Mower Deck Shell

The deck shell on zero-turn riding mowers is warranted to the **original purchaser** for five years from the date of purchase. Any defect in material or workmanship of the deck shell will be repaired free of charge (parts and labor) to the original purchaser for two years after the date of purchase. For the third through fifth year from the date of purchase, the parts required to repair a defect in material or workmanship of the deck shell, not the labor, will be provided free of charge.

Five-Year Limited Warranty on Main Frame

The main frame on zero-turn riding mowers is warranted to the **original purchaser** for five years from the date of purchase. Any defect in material or workmanship of the main frame will be repaired free of charge (parts and labor) to the original purchaser for two years after the date of purchase. For the third through fifth year from the date of purchase, the parts required to repair a defect in material or workmanship of the main frame, not the labor, will be provided free of charge.

90-Day Limited Warranty on Service Parts and Accessories

Genuine Ariens or Gravely brand service parts and accessories are warranted to be free from defects in material and workmanship for a period of 90 days after the date of purchase. An authorized Ariens or Gravely dealer will repair or replace any such part or accessory free of charge, except for labor, during that period.

The duration of all warranties herein applies only if the product is put to personal use around a household or residence. If the product is put to any business use, agricultural, commercial, or industrial, then the duration of these warranties shall be 90 days after the date of purchase. If any product is rented or leased, then the duration of these warranties shall be 90 days after the date of purchase.

Exceptions, Limitations, Exclusions

Customer Responsibilities

Register the product immediately at the time of sale. If the dealer does not register the product, the customer must complete the product registration card in the literature package and return it to the Ariens Company, or register the unit online at www.ariens.com or www.gravely.com.

To obtain warranty service, the **original purchaser** must:

- Perform the maintenance and minor adjustments explained in the owner's manual.
- Promptly notify Ariens or an authorized Ariens or Gravely service representative of the need for warranty service.
- Transport the product to and from the place of warranty service.
- Have the warranty service performed by an authorized Ariens or Gravely service representative.

To find an Ariens or Gravely authorized service representative, contact Ariens at:

655 W. Ryan Street
Brillion, WI 54110
(920) 756 - 2141
www.ariens.com
www.gravely.com

Exceptions and Limitations

- Batteries are warranted only for a period of 12 months after date of purchase, on a prorated basis. For the first 90 days of the warranty period, a defective battery will be replaced free of charge. If the applicable warranty period is more than 90 days, Ariens will cover the prorated cost of any defective battery, for up to 12 months after the date of purchase.

Exclusions – Items Not Covered by This Warranty

- Engines and engine accessories are covered only by the engine manufacturer's warranty and are not covered by this warranty.
- Eye-Q™ and Scan-Mate™ units are covered by their own warranty and are not covered by this warranty.
- Parts that are not genuine Ariens or Gravely service parts are not covered by this warranty.
- The following maintenance, service and replacement items are not covered by this warranty unless they are noted in the Limitations section above: lubricants, spark plugs, oil, oil filters, air filters, fuel filters, brake linings, brake arms, shoes, runners, scraper blades, shear bolts, mower blades, mower vanes, headlights, light bulbs, knives, cutters.
- Any misuse, alteration, improper assembly, improper adjustment, neglect, or accident which requires repair is not covered by this warranty.
- This warranty applies only to products purchased in the United States (including Puerto Rico) and Canada. In all other countries, contact place of purchase for warranty information.

Disclaimer

Ariens may from time to time change the design of its products. Nothing contained in this warranty shall be construed as obligating Ariens to incorporate such design changes into previously manufactured products, nor shall such changes be construed as an admission that previous designs were defective.

LIMITATION OF REMEDY AND DAMAGES

Ariens Company's liability under this warranty, and under any implied warranty that may exist, is limited to repair of any defect in workmanship, and repair or replacement of any defective part. Ariens shall not be liable for incidental, special, or consequential damages (including lost profits). Some states do not allow the exclusion of incidental or consequential damages, so the above limitation or exclusion may not apply to you.

DISCLAIMER OF FURTHER WARRANTY

Ariens Company makes no warranty, express or implied, other than what is expressly made in this warranty. If the law of your state provides that an implied warranty of merchantability, or an implied warranty of fitness for particular purpose, or any other implied warranty, applies to Ariens Company, then any such implied warranty is limited to the duration of this warranty. Some states do not allow limitations on how long an implied warranty lasts, so the above limitation may not apply to you.

This warranty gives you specific legal rights, and you may also have other rights which vary from state to state.



Ariens Company
655 West Ryan Street
Brillion, WI 54110-1072
920-756-2141
Fax 920-756-2407
www.ariens.com

 **WARNING** 

The engine exhaust from this product contains chemicals known to the State of California to cause cancer, birth defects or other reproductive harm.

ADDENDUM TO OWNER/OPERATOR MANUAL

PART NUMBERS: 03770600 & 03824400

The following information updates instructions in your owner/operator manual.

MAINTENANCE SCHEDULE PAGE GB-17

Interval	Task	Action
100 Hours or Every Season	Check All Belts	Replace worn or deteriorated belts. <ul style="list-style-type: none"> • Check hydrostatic belt (see <i>REPLACING HYDROSTATIC BELT</i> on page 25 for hydrostatic belt location). • Check PTO belt (see <i>REPLACING PTO BELT</i> on page 24 for PTO belt location).
	Check All Cables	Replace worn or improperly functioning PTO cables.

MOWER DECK REMOVAL AND INSTALLATION PAGE GB-19

Install (Figure 9)

1. Slide mower deck under unit.

NOTE: Perform step 2 and 3 for the right and left side of unit.

2. Connect drag link to front deck bracket.
3. Connect front and rear trunnions to lift arms.
4. Connect the PTO actuator cable to the deck idler arm and cable anchor.
5. Install PTO belt on the engine drive pulley (see *REPLACING PTO BELT* on page 24).

NOTE: Make sure the cable is taut, but not tight. The cable needs a slight amount of slack for the pulley brake to work correctly.

6. Level and adjust pitch of mower deck (see *LEVELLING AND ADJUSTING PITCH OF MOWER DECK* on page 20).

MOWER DECK REMOVAL AND INSTALLATION PAGE GB-20

The Distance From The Mower Blades To The Ground (Figure 10):

- In the lowest cutting position should be 1.5 in. \pm 1/4 in. (3.8 cm \pm 0.64 cm).
- In the highest cutting position should be 4.5 in. \pm 1/4 in. (11.4 cm \pm 0.64 cm).

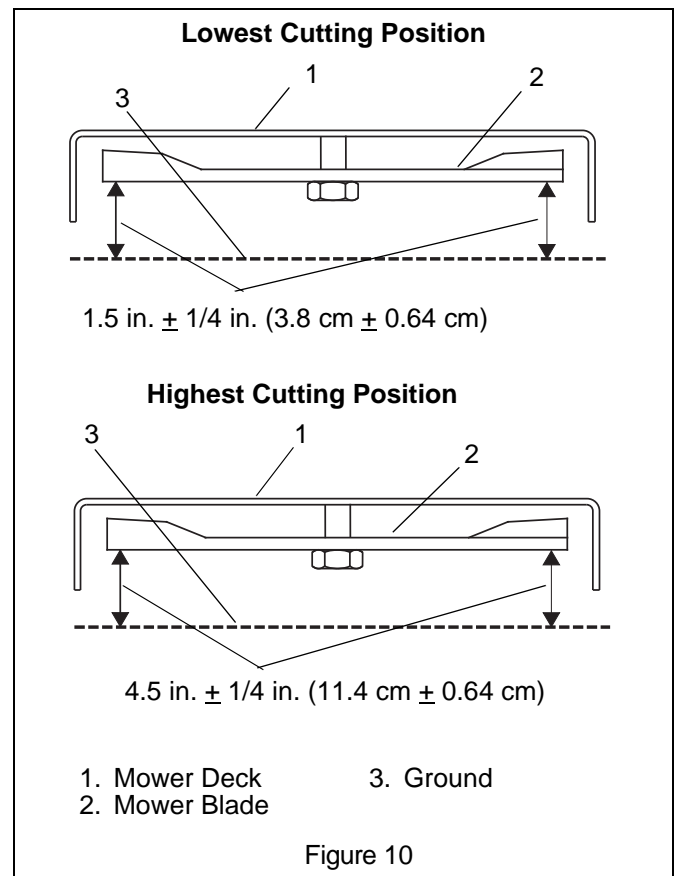

MOWER DECK REMOVAL AND INSTALLATION PAGE GB-25

Install (Figure 19)

NOTE: Do not install PTO belt on left mower deck pulley in step 1.

1. Install PTO belt on engine drive pulley and mower deck.
2. Pull idler arm towards outside of unit until PTO belt can be routed around left mower deck pulley.
3. Slowly release idler arm until idler pulley rests firmly against PTO belt.

4. Connect the PTO actuator cable to the deck idler arm.
5. Insert a shim of 0.10" (the thickness of 12-gauge steel) between the roller on the idler arm and the deck sheave. With the shim in place, pull the actuator cable taut and then tighten the cable adjustment nuts against the cable mount bracket to hold the setting.
6. Remove the shim and check for a gap between the roller and the deck sheave.
7. Install belt covers on mower deck.

NOTE: Ensure that belt is still positioned in the groove of the sheave after belt covers are installed.

SPECIFICATIONS PAGE GB-29

SPECIFICATIONS	
Mower Deck	
Cutting Height – in. (cm)	1.5 – 4.5 (3.8 – 11.4)